

MONASH UNIVERSITY
DEPARTMENT OF ELECTRICAL & COMPUTER SYSTEMS ENGINEERING
Performance of Telecommunication Networks

Experiment V: Delay and Queueing in Packet Switching Networks

Y. Ahmet Şekercioğlu

Aims

In this experiment, we will learn the fundamentals of modeling and simulating packet switching networks, and compare the results of theoretical delay calculations of networks of M/M/1 (FIFO) queues against the results of the simulation runs.

Introduction and Preliminary Work

The queueing diagram of our example network is given in Figure 1. It consists of a single packet switch and two hosts communicating through the packet switch. There are M/M/1 (FIFO) queues connected to each outgoing link. Assume that each link has 1 Mb/s transmission capacity and propagation delay is 1 ms.

Since we want to model M/M/1 queues, we want to generate Poisson traffic. If we randomly choose packet sizes and inter-arrival times from an exponential distribution we should be able to obtain what we want.

Let's choose average packet size as 10000 bits. By increasing or decreasing the inter-arrival times we can vary the link load (called offered load). As an example, say we want an offered link load of 60%. 60% of 1 Mbits/sec is 600000 bits/sec. On average then, we want to generate 600000 bits/sec to load the link to 60% of its capacity. If the average packet

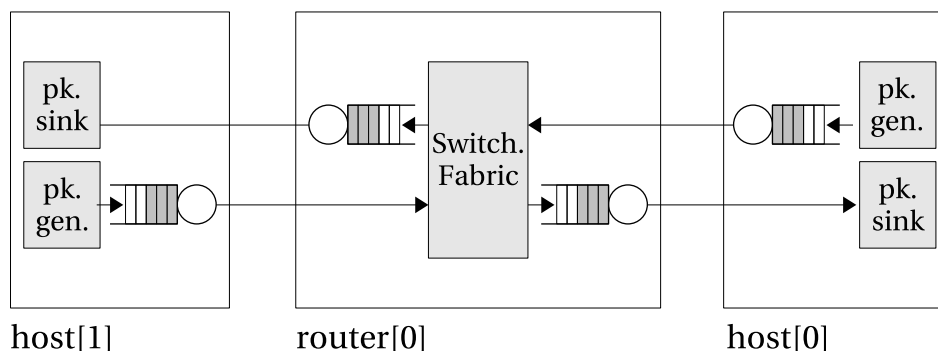

Figure 1: Queueing diagram of our network. The router is modeled as an output-queued switch. All the links connecting the hosts and the router have 1 Mb/s transmission capacity. Also, one way propagation delay between hosts and the router is 1 ms.

OFFERED LOAD	AVERAGE PACKET SIZE	AVERAGE INTERARRIVAL TIME
20%	10000 bits	
40%	10000 bits	
60%	10000 bits	0.0167 seconds
80%	10000 bits	
90%	10000 bits	
95%	10000 bits	
98%	10000 bits	

Table 1: Offered link loads Vs interarrival times for our network of single packet switch.

QUEUE LENGTH STATISTICS									
OFFERED LOAD	router [0] .pk_queue [0]				router [0] .pk_queue [1]				
	AVERAGE DELAY		AVERAGE Q LENGTH		AVERAGE DELAY		AVERAGE Q LENGTH		
	CALC.	MEAS.	CALC.	MEAS.	CALC.	MEAS.	CALC.	MEAS.	
20%									
40%									
60%									
80%									
90%									
95%									
98%									

Table 2: Queue statistics

size is 10000 bits, $600000/10000 = 60$ packets/sec. should be generated. This means that, average interarrival time should be $1/60 = 0.0167$ sec. for an offered link load of 60% for this network.

If you are convinced that my logic is correct, please complete the Table 1. Then, by using the fundamental M/M/1 queue equations we have discussed in the lectures, calculate the average queue lengths and end-to-end packet delays, and write them in the “CALC” columns of the Tables 2 and 3.

Exercise - A Network of Two Hosts and a Packet Switch

I have designed and implemented a set of simple models (hosts, packet generators and sinks, and routers modeled as output queued switches) for simulating packet switching networks. The model files are accessible through this Web page: <http://ctiware.eng.monash.edu.au/twiki/bin/view/Simulation/ANetworkOf4HostsAnd2PacketSwitches>. In the example given in the Web page, the simulated network topology consists of four hosts and two routers. We will not use this topology. Instead, we will create a simpler network of one router and two hosts. You can find the NED file of this network in Appendix A.

Let’s run our first packet switching network simulation experiment:

1. Copy all the files given in the Web page above except the network model and the

END-TO-END PACKET DELAY STATISTICS								
OFFERED LOAD	host[0] sink				host[1] sink			
	AVERAGE PK. SIZE		AVERAGE E-E DELAY		AVERAGE PK. SIZE		AVERAGE E-E DELAY	
	CALC.	MEAS.	CALC.	MEAS.	CALC.	MEAS.	CALC.	MEAS.
20%								
40%								
60%								
80%								
90%								
95%								
98%								

Table 3: Packet statistics

omnetpp.ini. Instead, use the ones provided in In Appendices A and B.

2. Generate the executable file of the simulation by following the steps you have learnt in the previous experiments.
3. Start running the simulation to view the main graphical user interface window, but do not press the “run” button yet. We need to open up some more windows to observe the progress of queues and packet size distributions:
 - (a) Double-click on host[1] icon to view the model components.
 - (b) Double-click on app_sink icon, click on “Contents” tab.
 - (c) Double-click on pkSizeStats (a window with light blue background should open).
 - (d) Double-click on pkDelayVector (a window with light yellow background should open).
 - (e) Double-click on router[0] icon to view the model components.
 - (f) Double-click on pk_queue[1], click on “Contents” tab.
 - (g) Double-click on qLengthVector (a window with light yellow background should open).
 - (h) Double-click on qLengthStats (a window with light blue background should open).
4. Now, click on the “fast” run button to start the simulation and observe the statistics windows.
5. Have a look at the histograms and interpret them.
6. When the simulation completes (controlled by sim-time-limit in the omnetpp.ini file), it dumps plenty of statistics. Locate the relevant ones and fill in the “CALC” columns of the Tables 2 and 3 belonging to the row 60% offered link load. Do measured values and calculated values match?

7. Now obtain the measured values for the remaining offered link loads and compare calculated and measured values.
→ Show the completed tables to your laboratory supervisor.
8. Plot the graph of offered link load Vs average queue size for both router queues `router[0].pk_queue[0]` and `router[0].pk_queue[1]`. Compare the graph with Figure 8.5 of [Sta02]. Do they match?
→ Show the graph to your laboratory supervisor.

A Topology Description (NED file) of the `single_pkswitch_net`

```
1  import "host";
2  import "router";
3
4  channel adslLink
5      delay 1ms;
6      datarate 1000000; // bits/sec
7  endchannel
8
9  module TwoHostsNet
10     submodules:
11         host: Host[2];
12         parameters:
13             address = index;
14             display: "i=device/pc2";
15         router: Router[1];
16         parameters:
17             address = index + sizeof(host);
18             display: "i=abstract/router";
19     connections:
20         host[0].out++ --> adslLink --> router[0].in++;
21         host[0].in++ <-- adslLink <-- router[0].out++;
22
23         host[1].out++ --> adslLink --> router[0].in++;
24         host[1].in++ <-- adslLink <-- router[0].out++;
25 endmodule
26
27 network single_pkswitch_net :
28     TwoHostsNet
29 endnetwork
```

B `omnetpp.ini` File of the `single_pkswitch_net`

```
1  [General]
2  network = single_pkswitch_net
3  rng-class = "cMersenneTwister"
```

```
4 num-rngs = 1
5 seed-0-mt = 1000
6 sim-time-limit = 600 # seconds
7 preload-ned-files=*.ned
8
9 [Tkenv]
10 default-run=1
11
12 [Parameters]
13 single_pkswitch_net.host[0].destAddressList = "1"
14 single_pkswitch_net.host[1].destAddressList = "0"
15 single_pkswitch_net.**.pkSize = pk_geometric(500,8000) # min. packet size: 500 bits
16                                                         # avg. packet size: 8000 bits
17 single_pkswitch_net.**.pk_queue[*].pkCapacity = 1000000 # packets
18                                                         # queue capacity
19                                                         # (almost infinite)
20 [Run 1]
21 description="60% link utilization"
22 single_pkswitch_net.**.iaTime = exponential(0.0167) # seconds
```

References

- [Sta02] W. Stallings. *High-Speed Networks and Internets: Performance and Quality of Service*. Prentice Hall, 2nd edition, 2002.